

## Force transducers RCA series

Very favourable price / performance ratio

Nominal forces from 50N to 2.000 N

Large measuring range up to 1:100

Accuracy class up to 0.1%

Adapter for axes diameters up to 40mm

Mounting type

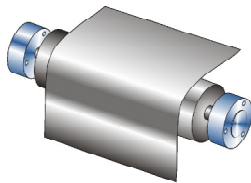

### FORCE SENSOR

The RCA series **force sensor** offers compact dimensions and is designed for measuring the tension on moving material webs where deflection rollers with rigid axes are used. Flexible mounting options include the ability to install the force transducer either with four fasteners from the front or with a single fastener from the rear.

**Adapter** for different axes diameters. Like all HAEHNE web tension sensors, the inner part acts as a double bending beam system with the familiar properties thanks to its special design:

- high linearity
- high rigidity

**HAEHNE force measuring bearings** with strain gauges in a full bridge circuit provide very precise signals even with a small wrap angle and low material tension.

A downstream **measuring amplifier** from the HAEHNE range processes the measuring signals and feeds the strain gauge full bridge.

### OPTIONS

Angled plug connection

**S1:** M12 (Metal)

**S2:** M12 (injected)

Straight connector

**N1:** M12 (Metal)

**N2:** M12 (injected)

Plug connection with cable

**W5:** 5m cable

**W10:** 10m cable

**W20:** 20m cable

### ADVANCED OPTIONS

**F:** Designed for operation in hazardous areas, incl. J-Box

Increased accuracy

**G3:** 0,1%

Increased temperature

**H1:** up to 120°C

### STANDARD CONNECTION

Plug connection S1

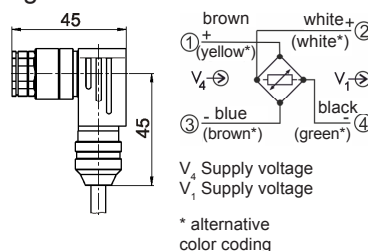

### ORDERING EXAMPLE

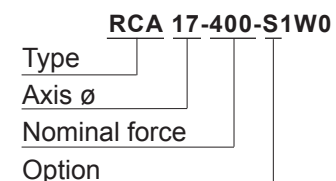

### SCOPE OF DELIVERY

Force sensor with adapter and connector plug

Standard connection S1W0:  
Self-assembly cable socket (no cable)

### ADDITIONALLY AVAILABLE

- Mounting bracket
- Connection cable (pre-assembled)
- Measuring amplifier

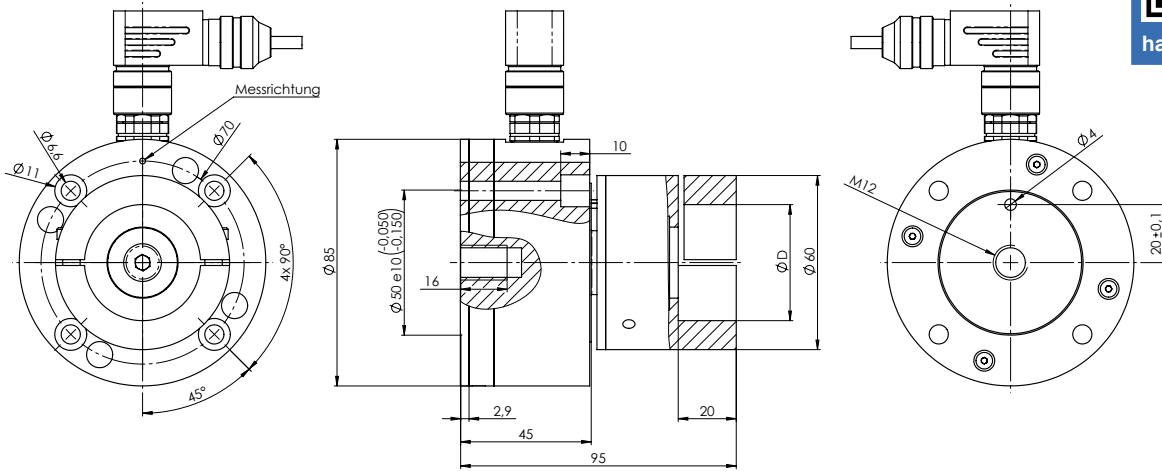

## RCA-SERIES: MOUNTING OPTIONS

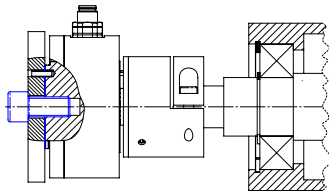
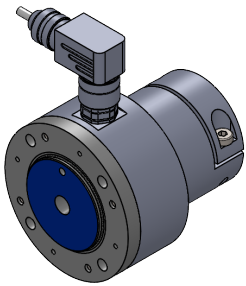

Mounting via center with 1x M12

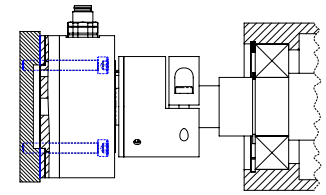
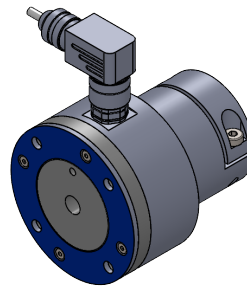

Mounting via flange with 4x M6

TECHNICAL DATA	VALUES (%) BASED ON NOMINAL FORCE
Nominal forces (N)	50; 125; 250; 500; 1000; 1500; 2000
Max. operating force	160%
Absolute max. force	1000%
Nominal rating	1,5 mV/V
Accuracy	0,3%
Reproducibility	0,05%
Measuring range	1:100
Nominal temperature range	+10...+60°C
Operating temperature range	-10...+70°C
Nominal resistance	1000 Ohm
Max. Supply voltage	10 VDC
Protection class	IP 42
Material	Stainless steel

ADAPTER SIZES
RCA 17 = 17mm
RCA 20 = 20mm
RCA 25 = 25mm
RCA 30 = 30mm
RCA 35 = 35mm
RCA 40 = 40mm



follow us on  
LinkedIn