

## Force sensor RCZ-series

Very favorable price/performance ratio

Nominal forces from 50 N to 2.000 N

Large measuring range up to 100:1

Accuracy class up to 0.1%

Simple mounting of standard pulleys



Made in Germany

### Mounting type

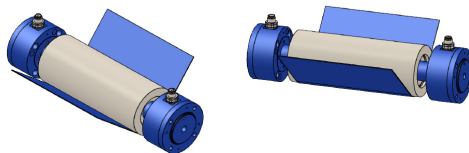

### FORCE SENSOR

The **RCZ-series** force sensor offers compact dimensions and is designed for measuring the tensile force on running material webs for rollers with integrated roller bearings, without an axle.

The flexible mounting options include the possibility of installing the force transducer either with four fasteners from the front or with a single fastener from the rear.

Like all **HAEHNE** web tension sensors, the inner part acts as a double bending beam system with the familiar properties thanks to its special design:

- high linearity
- high rigidity

**HAEHNE** force measuring bearings with strain gauges in a full bridge circuit provide very precise signals even with a small wrap angle and low material tension. A downstream measuring amplifier from the **HAEHNE** program processes the measurement signals and feeds the strain gauge full bridge.

### OPTIONS

Angled plug connection

**S1:** M12 (Metal)

**S2:** M12 (injected)

Straight connector

**N1:** M12 (Metal)

**N2:** M12 (injected)

Plug connection with cable

**W5:** 5m cable

**W10:** 10m cable

**W20:** 20m cable

### ADVANCED OPTIONS

**F:** Designed for operation in hazardous areas, incl. J-Box

Increased accuracy

**G3:** 0,1%

Increased temperature up to

**H1:** 120°C

**H1.5:** 150°C with cable gland "T" and 5m Teflon cable

Vacuum version

**V:** up to 10<sup>-7</sup> millibar

### STANDARD CONNECTION

Plug connection S1

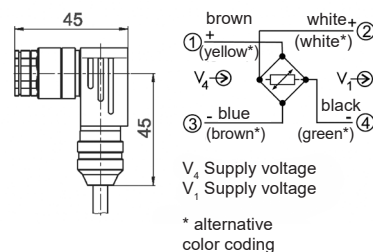

### ORDERING EXAMPLE

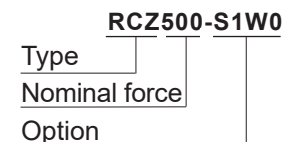

### SCOPE OF DELIVERY

Force sensor with adapter and cable socket

Standard connection S1W0:  
Self-assembly cable socket (metal) 90° angled without cable

### ADDITIONALLY AVAILABLE

- Mounting bracket (alternative mounting)
- Connection cable (pre-assembled)
- Measuring amplifier

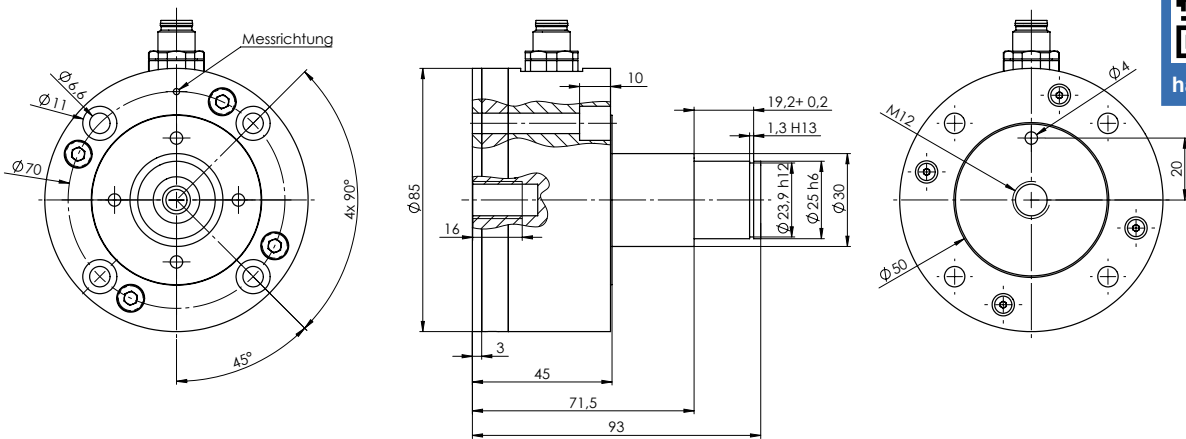

**RCZ-SERIES: MOUNTING OPTIONS**

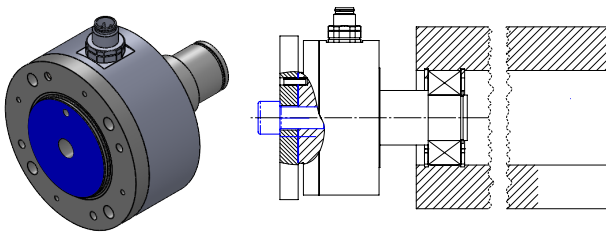

Mounting via center with 1x M12

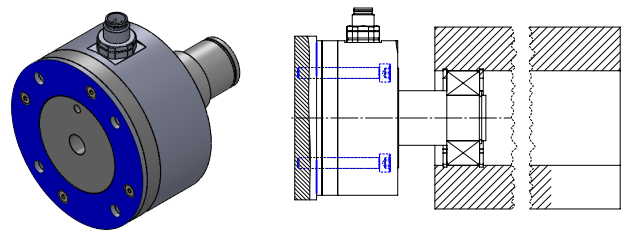

Mounting via flange with 4x M6

Technical data	Values (%) based on nominal force
Nominal forces (N)	50; 125; 250; 500; 1000; 1500; 2000
Max. operating force	160%
Absolute max. force	1000%
Nominal rating	1,5 mV/V
Accuracy	0,3%
Reproducibility	0,05%
Measuring range	100:1
Nominal temperature range	+10...+60°C
Operating temperature range	-10...+70°C
Nominal resistance	1000 Ohm
Max. Supply voltage	10 VDC
Protection class	IP 42
Material	Stainless steel



follow us on  
LinkedIn